







TITLE: IO Board		REV: 1.0
 	Company: JMC Lab Experience	Sheet: 1/5
	Date: 2022-01-09	Drawn By: JMC



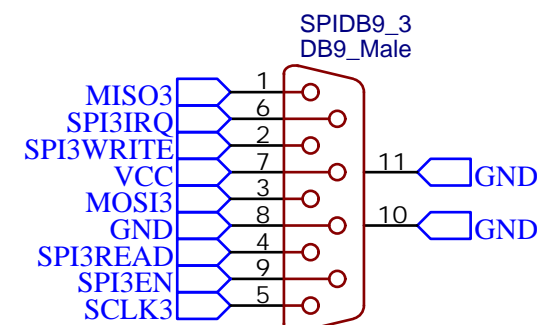
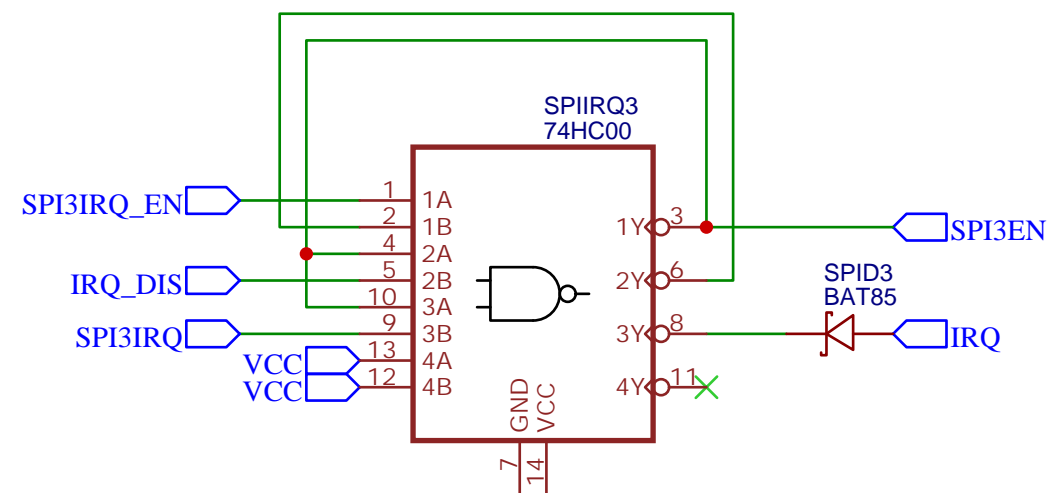
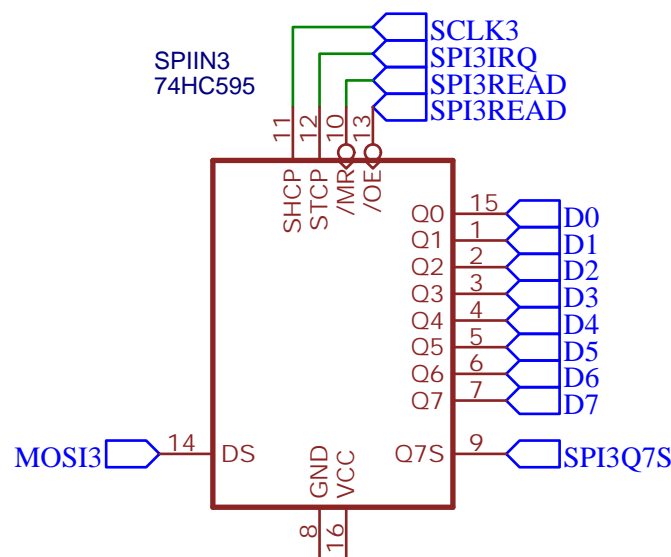
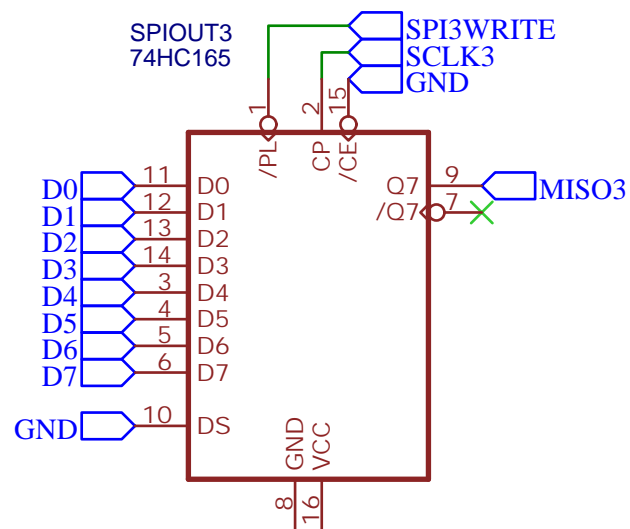
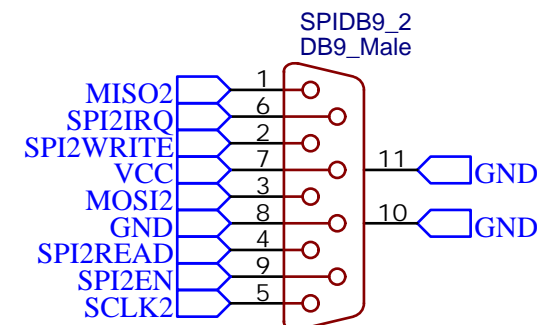
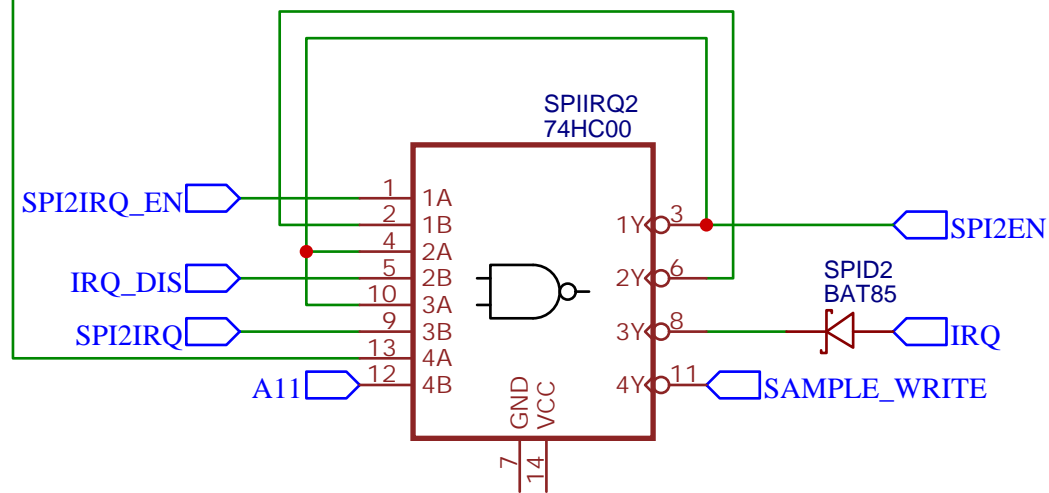
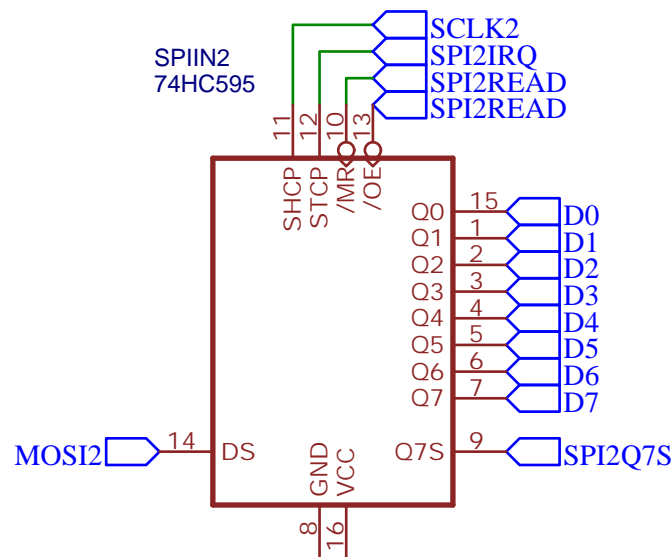
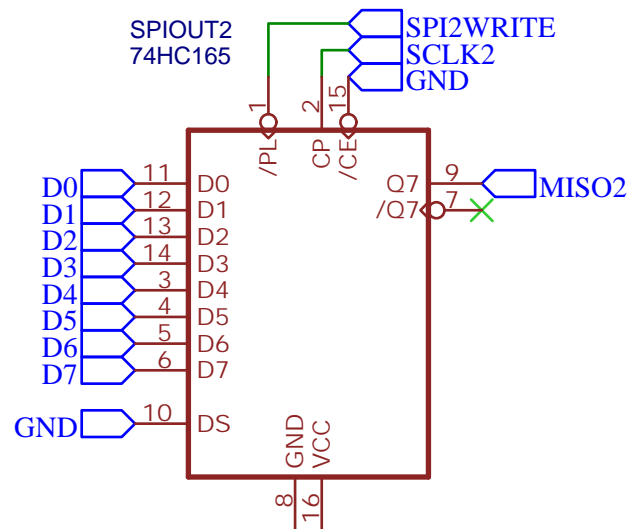
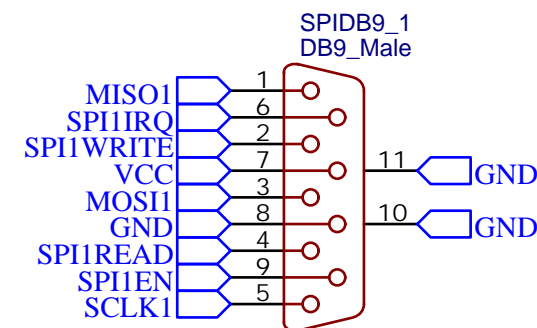
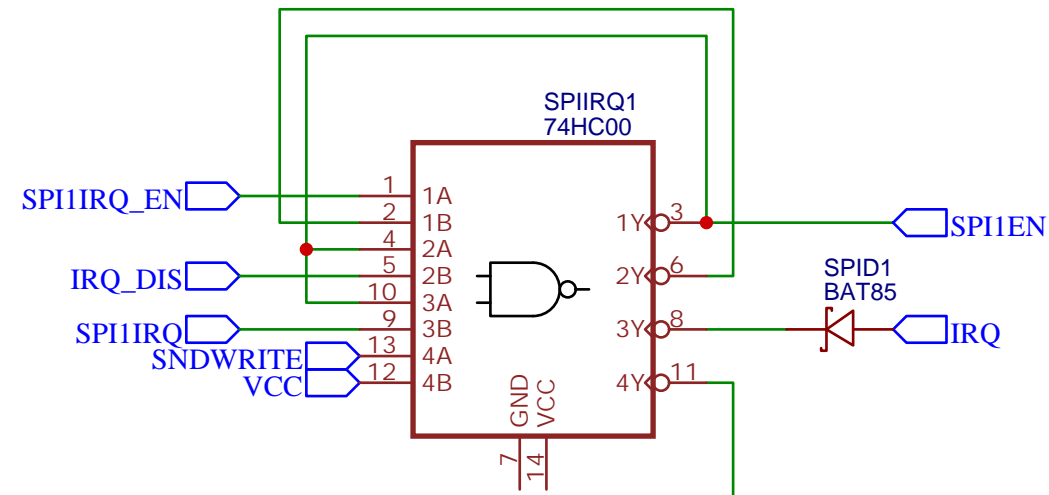
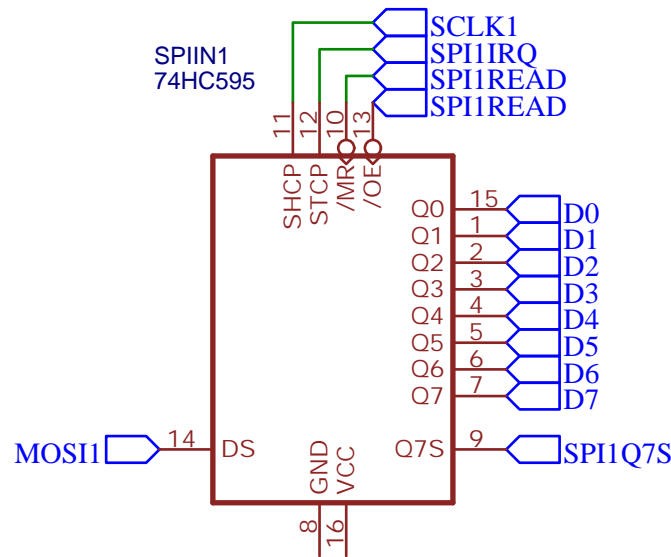
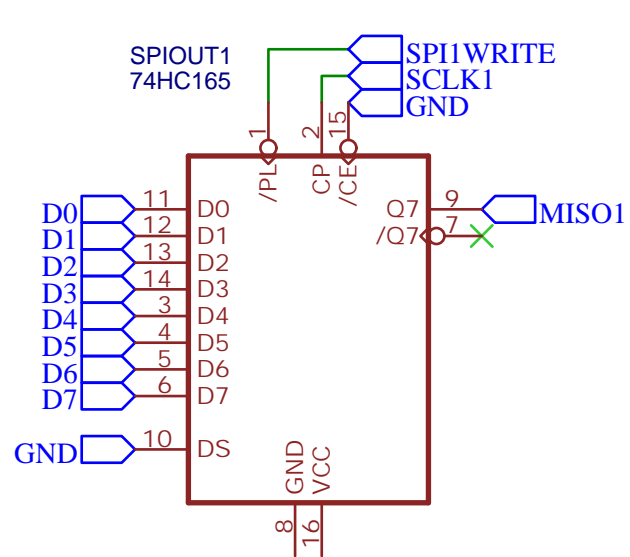

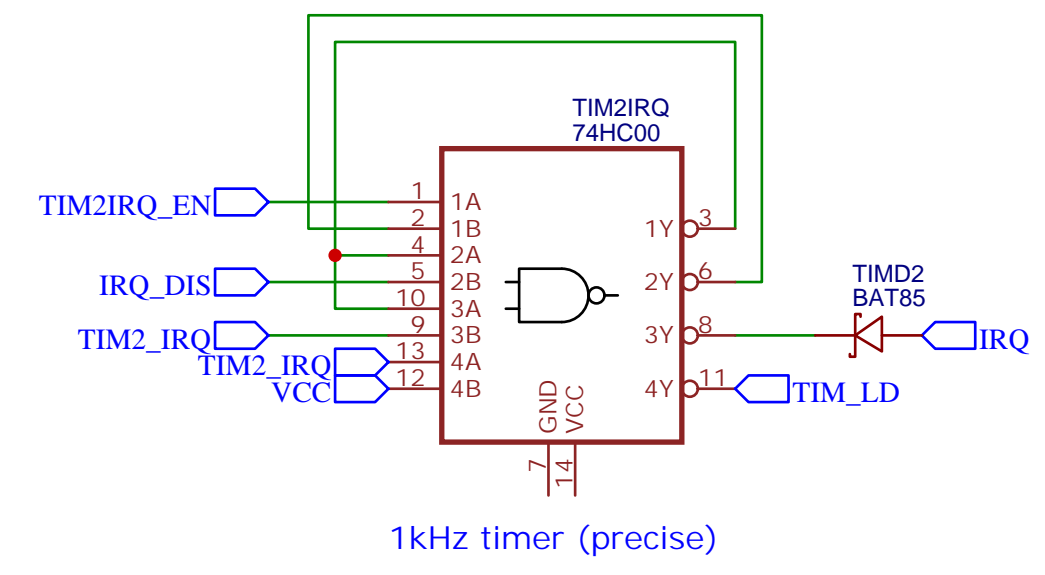
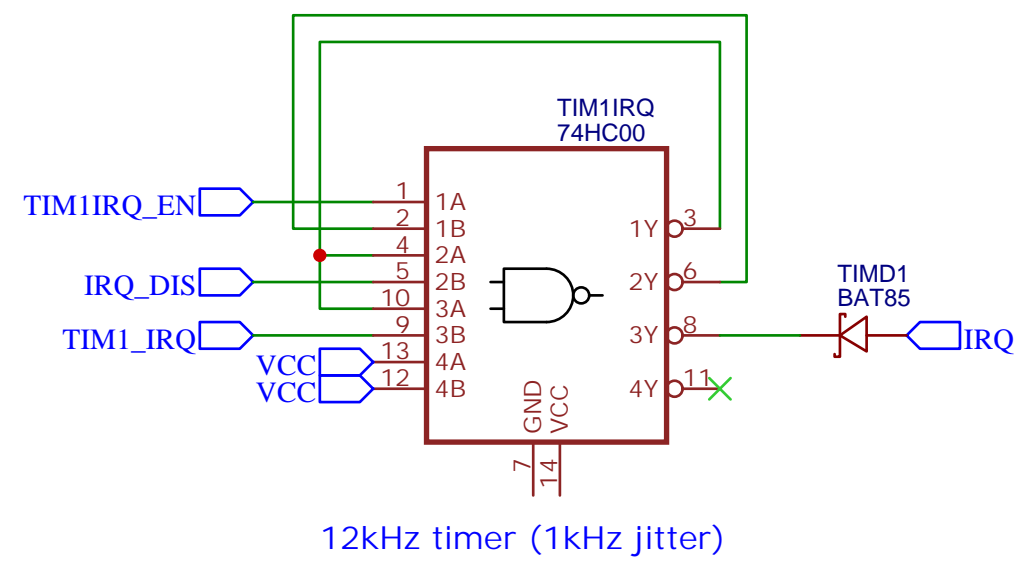
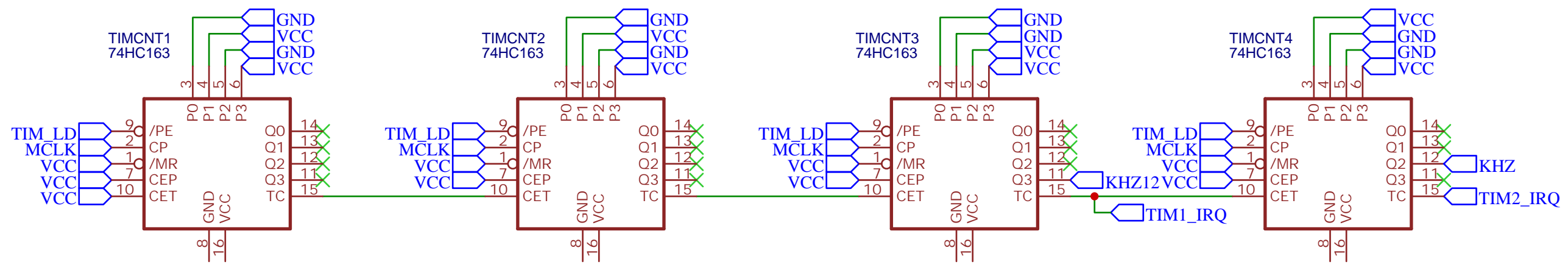
TITLE: IO Board		REV: 1.0
 	Company: JMC Lab Experience	Sheet: 2/5
	Date: 2022-01-09	Drawn By: JMC



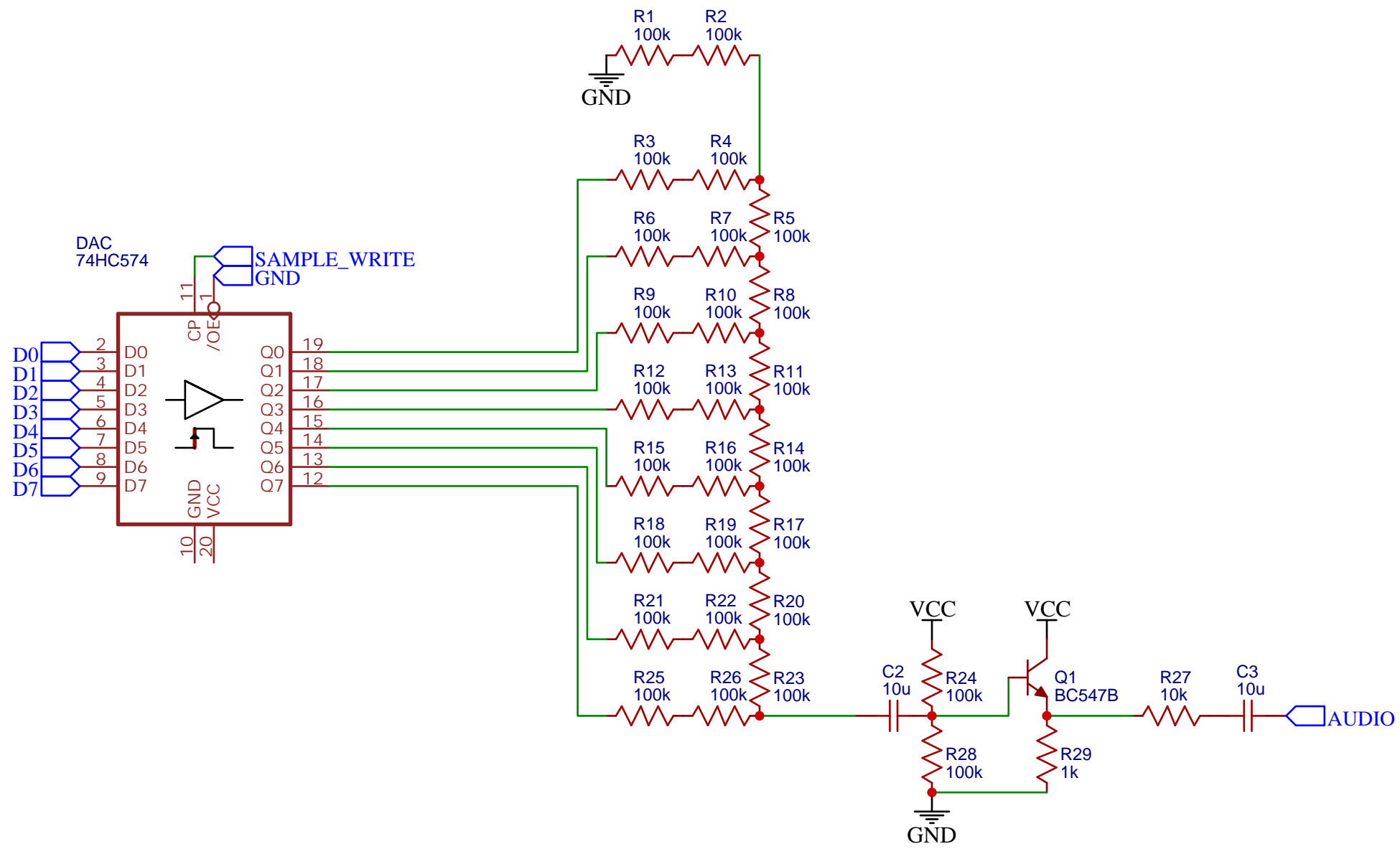

TITLE: IO Board		REV: 1.0
 	Company: JMC Lab Experience	Sheet: 3/5
	Date: 2022-01-09	Drawn By: JMC

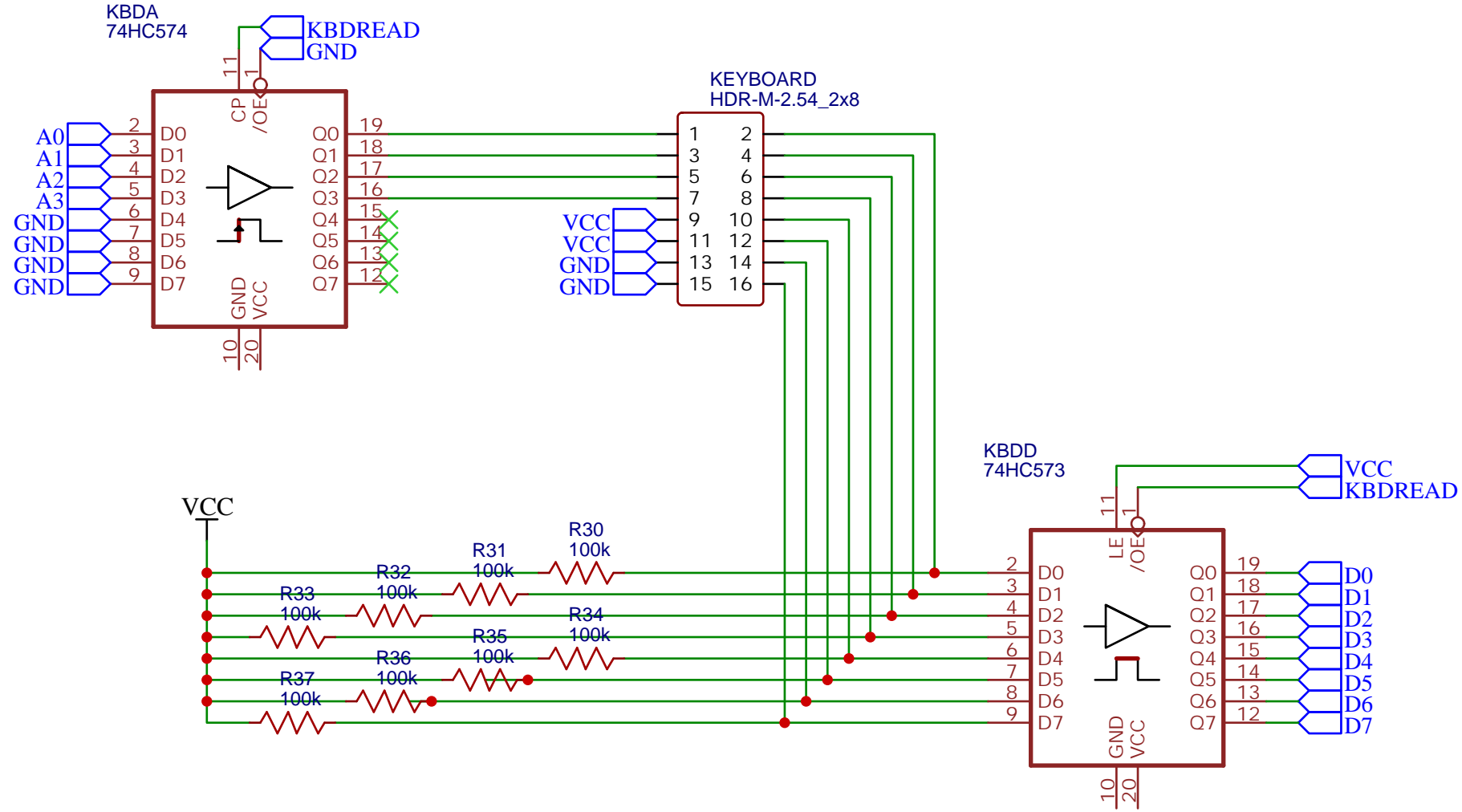

TITLE: IO Board		REV: 1.0
 	Company: JMC Lab Experience	Sheet: 5/5
	Date: 2022-01-09	Drawn By: JMC



TITLE: IO Board		REV: 1.0
 	Company: JMC Lab Experience	Sheet: 4/5
	Date: 2022-01-09 Drawn By: JMC	